

Measuring electronic sensor of d.c., a.c., pulsating currents with a galvanic insulation between primary and secondary circuits.  
Capteur électronique de mesure de courants d.c., a.c., impulsions, avec isolation galvanique entre circuits primaire et secondaire.

RoHS  
compliant

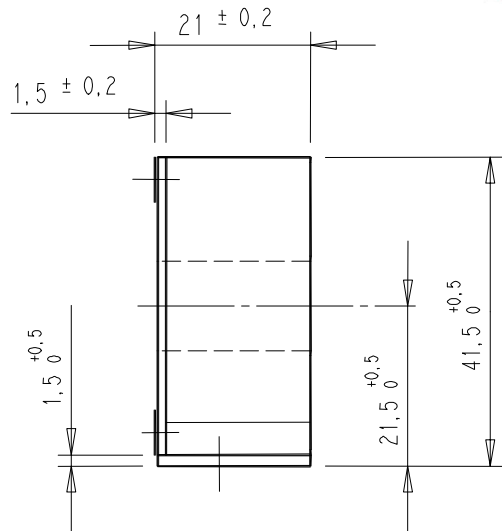
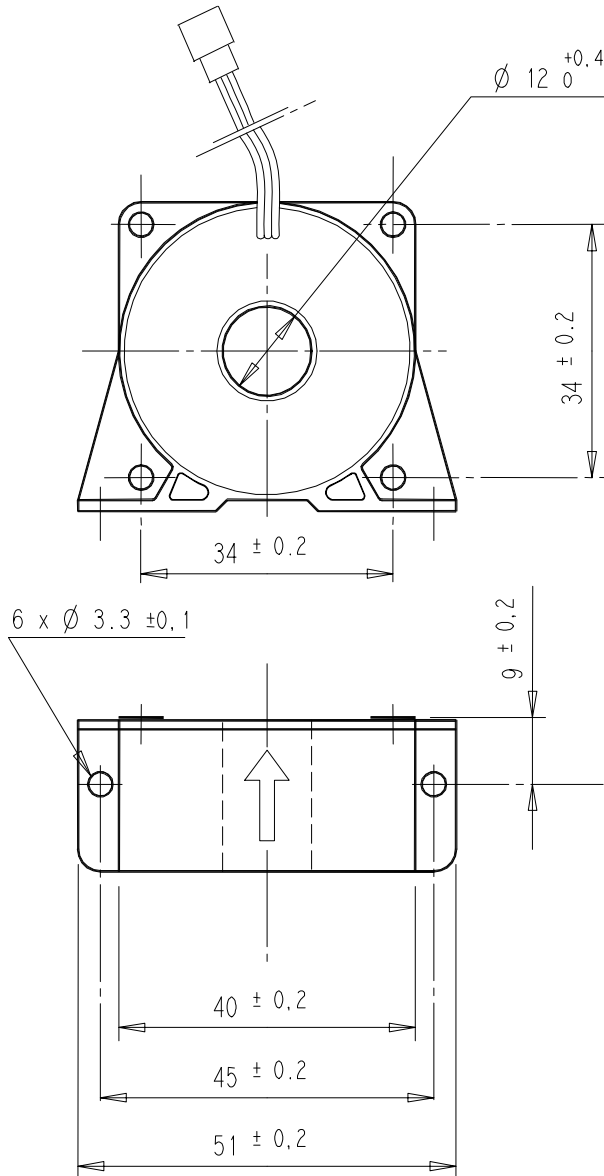

**SECONDARY CONNECTIONS /  
RACCORDEMENT SECONDAIRE**

**3 wires length / 3 fils longueur : 120 mm ±10**

**CONNECTOR / CONNECTEUR**

**Case / Boîtier : Tyco 1375820-3**

**Contacts / Contacts : Tyco 1375819-2**

**TERMINAL MARKING / REPERAGE SORTIES**

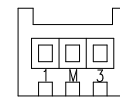

1 2 3

1 : +  
2 : M  
3 : -

**General tolerance: ±1 mm**  
Tolérance générale : ±1 mm

## GENERAL DESCRIPTION

Coated electronic circuit

Self extinguishing plastic case

**Direction of the secondary current: A primary current flowing in the direction of the arrow results in a positive output current from M terminal.**

**Protections:**

- Of the measuring circuit against short-circuits
- Of the measuring circuit against opening

**Instructions for use and mounting according to our catalogue**

## DESCRIPTION GENERALE

Circuit électronique enrobé

Boîtier en matière isolante auto-extinguible

**Sens du courant secondaire : Un courant primaire circulant dans le sens de la flèche engendre un courant secondaire sortant par la borne M.**

**Protections :**

- Du circuit de mesure contre les court-circuits
- Du circuit de mesure contre l'ouverture

**Instructions de montage et d'utilisation suivant notre catalogue**

## CHARACTERISTICS

## CARACTERISTIQUES

<b>Nominal primary current (<math>I_{PN}</math>)</b>	<i>Courant primaire nominal (<math>I_{PN}</math>)</i>	<b>A r.m.s. (<math>A_{eff}</math>)</b>	: 100
<b>Measuring range (<math>I_P</math> max)</b>	<i>Plage de mesure (<math>I_P</math> max)</i>	<b>A peak (<math>A_{crête}</math>)</b>	: $\pm 165$ (1mn/h)
<b>Max. measuring resistance (<math>R_M</math> max)</b>	<i>Résistance de mesure max. (<math>R_M</math> max)</i>	<b><math>\Omega</math></b>	: 38 (@ $I_{Pmax}$ / $\pm 15V$ ( $\pm 10\%$ ))
<b>Min. measuring resistance (<math>R_M</math> min)</b>	<i>Résistance de mesure min. (<math>R_M</math> min)</i>	<b><math>\Omega</math></b>	: 17 (@ $I_{PN}$ / $\pm 15V$ ( $\pm 10\%$ ))
<b>Not measurable overload</b>	<i>Surcharge non mesurable</i>	<b>A peak (<math>A_{crête}</math>)</b>	: $\leq 300$ (1ms/h)
<b>Turn ratio (<math>N_P/N_S</math>)</b>	<i>Rapport de transformation (<math>N_P/N_S</math>)</i>		: 1/1000
<b>Secondary current (<math>I_S</math>) at <math>I_{PN}</math></b>	<i>Courant secondaire (<math>I_S</math>) à <math>I_{PN}</math></i>	<b>mA</b>	: 100
<b>Accuracy at <math>I_{PN}</math></b>	<i>Précision à <math>I_{PN}</math></i>	<b>%</b>	: $\leq \pm 0.4$ (@ +25°C)
<b>Accuracy at <math>I_{PN}</math></b>	<i>Précision à <math>I_{PN}</math></i>	<b>%</b>	: $\leq \pm 1$ (-5°C ... +70°C)
<b>Offset current (<math>I_{S0}</math>)</b>	<i>Courant résiduel (<math>I_{S0}</math>)</i>	<b>mA</b>	: $\leq \pm 0.4$ (@ +25°C)
<b>Linearity</b>	<i>Linéarité</i>	<b>%</b>	: $\leq 0.1$
<b>Thermal drift coefficient</b>	<i>Coefficient de dérive thermique</i>	<b>mA/°C</b>	: $\leq 0.01$ (-5°C ... +70°C)
<b>Delay time</b>	<i>Temps de retard</i>	<b><math>\mu S</math></b>	: $\leq 1$
<b>di/dt correctly followed</b>	<i>di/dt correctement suivi</i>	<b>A/<math>\mu s</math></b>	: $\leq 50$
<b>Bandwidth</b>	<i>Bande passante</i>	<b>kHz</b>	: 0 ... 100 (-1dB)
<b>No-load consumption current (<math>I_{A0}</math>) (Consumption = <math>I_{A0} + I_S</math>)</b>	<i>Courant de consommation à vide (<math>I_{A0}</math>) (Consommation = <math>I_{A0} + I_S</math>)</i>	<b>mA</b>	: $\leq 8$ (@ $\pm 15V$ ( $\pm 10\%$ ))
<b>Voltage drop (e)</b>	<i>Tension de déchet (e)</i>	<b>V</b>	: $\leq 2.5$
<b>Secondary resistance (<math>R_S</math>)</b>	<i>Résistance secondaire (<math>R_S</math>)</i>	<b><math>\Omega</math></b>	: $\leq 30$ (@ +70°C)
<b>Dielectric strength</b>	<i>Rigidité diélectrique</i>		
<b>Primary / Secondary</b>	<i>Primaire / Secondaire</i>	<b>kVr.m.s. (<math>kV_{eff}</math>)</b>	: 3 (50Hz, 1min)
<b>Supply voltage</b>	<i>Tension d'alimentation</i>	<b>V d.c.</b>	: $\pm 15$ ( $\pm 10\%$ )
<b>Mass</b>	<i>Masse</i>	<b>Kg</b>	: 0.05
<b>Operating temperature</b>	<i>Température de service</i>	<b>°C</b>	: -20 ... +70
<b>Storage temperature</b>	<i>Température de stockage</i>	<b>°C</b>	: -25 ... +85
<b>Temperature of primary conductor in contact with the sensor</b>	<i>Température du conducteur primaire en contact avec le capteur</i>	<b>°C</b>	: $\leq 100$

## Particularities

## Particularités

The characteristics detailed in this leaflet are subject to change without prior notice

C\_ES\_10.doc



AEROSPACE  
& DEFENCE



COACHES  
& BUSES



RAILWAY



INDUSTRY



ENERGY



PLEASURE  
BOAT



VERTICAL  
TRANSPORT



INDUSTRIAL  
VEHICLES



OFFSHORE  
& MINING

PETERCEM . com

Noncontractual text & photographs